

MANISCOPIC

MLT 526

"Compact"

- Maximum lifting height : 5.15 m
- Capacity : 2600 kg
- Maximum forward reach : 2.90 m
- Torque convertor

STANDARD OR
LOW PROFILE CAB
VERSIONS AVAILABLE



MLT 526 T compact with a Bugnot Grifbal S



MLT 526

 **Lifting capacity**2600 kg
at 500 mm from forks heels.
Tipping load
at maximum reach1830 kg
Tear out force with bucket
to ISO 8313.....4550 kg

 **Lifting height**5.15 m
Times : unladen / loaded (in s)
Lifting..... Atmo Turbo
.....7.2/7.5.....6.8/7.1
Lowering.....5.1/5.0.....4.8/4.7
Boom extension.....4.2/4.3.....4.0/4.1
Boom retraction.....2.2/2.2.....2.0/2.0
Time unladen (in s)
Crowd3.53.73
Dump.....2.82.7

 **Tyres**
400/70-20

 **Forks** (mm)
Length1200
Width125
Carriage rotation154°

 **Oil bath multidisc brakes on front/rear axle**

 **Perkins engine**
Type1004.42/1004.40 T
Atmo.....4233 cm³
Turbo3990 cm³
Power (ISO/TR 14396)
Atmo86 HP/63 kw
Turbo101 HP/74.6 kw
Maximum torque
Atmo300 Nm at 1400 tr/mn
Turbo402.5 Nm at 1400 tr/mn
Direct injection
Water cooling

 **Transmission**Torque Convertor
Electro - hydraulic reversing shift
4 speeds forward and reverse
Maximum travel speed25 km/h

 **Hydraulics**
Lifting/tilting pump :
gear type Atmo250 bars/85 l./mn
Turbo250 bars/90 l./mn
Flow divider with priority to steering

 **Capacities**
Cooling system17.25 l.
Engine oil8 l.
Hydraulic oil135 l.
Transmission oil.....11 l.
Fuel tank.....104 l.

 **Weight unladen** (with forks) : Atmo5785 kg
Turbo5755 kg
.....2.01 m

Overall width.....
Overall height
MLT 526 compact/MLT 526 T compact2.06 m
MLT 526 T2.21 m
Turning radius (outside wheels).....3.69 m
Overall length4.51 m
Ground clearance0.4 m
Drawbar pull :
MLT 526 compact5500 daN
MLT 526 T/MLT 526 T compact6100 daN

"TAILOR MADE" DIMENSIONS

Overall width : 2.01 m
Overall length : 4.51 m

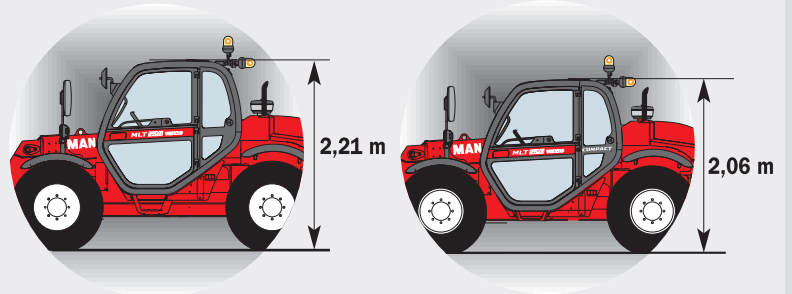

STANDARD LEVEL CAB
(Turbo)

LOW PROFILE CAB
"Compact" version
(Atmo or Turbo)

Reach at maximum height : 0,67 m

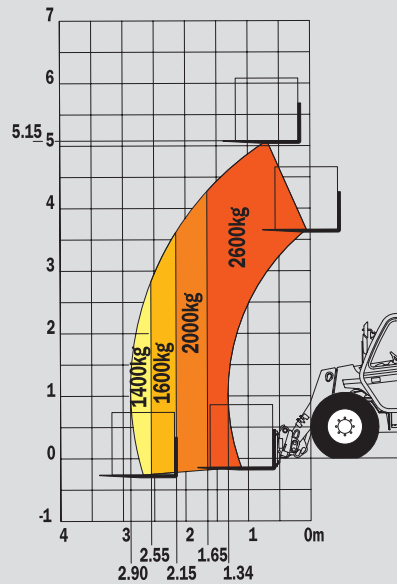

Under EN 1459 annexe B

	MLT 526 Compact	MLT 526 T Compact
A	1200	1200
B	2520	2520
C	1130	1135
C1	1060	1060
D	4510	4515
D1	4400	4400
D2	3920	3920
E	5710	5715
F	1600	1600
F1	1600	1600
G	400	400
G1	365	365
G2	365	365
I	860	860
J	866	866
K	1040	1163
L	40	45
N (a)	1476	1465 at 1490
N (b)	-	1615 at 1640
O	125	125
P2	41°	41°
P3	39°	39°
R	3485	3485
S	7280	7285
T	3645	3685
U1 (a)	2060	2060
U2 (b)	2215	2320
V	4675	4675
V1	1400	1400
V2	3690	3690
W	2010	2010
Y	12°	12°
Z	142°	142°

(mm)

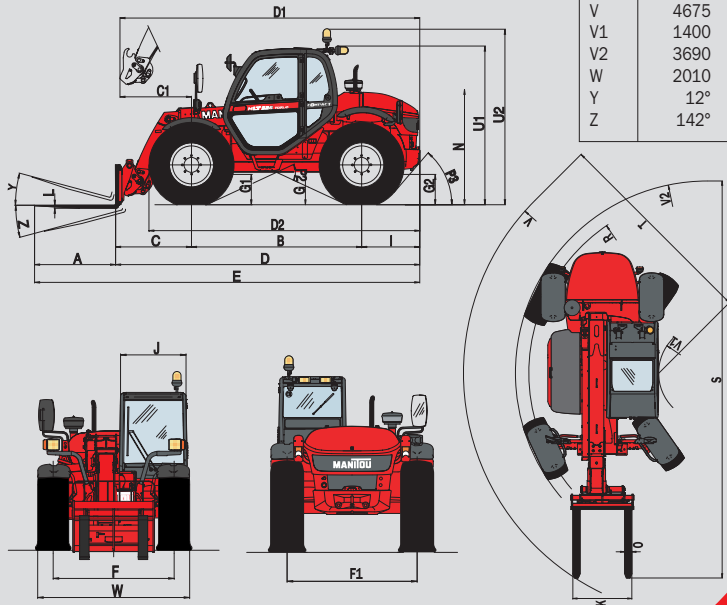

This publication in no way constitutes an offer and the company reserves the right to alter specification without prior notice. The MANITOU models presented in this brochure can be supplied complete with optional equipment attachments.



MANITOU B.F. S.A.
B.P.249 - 44158 ANCENIS CEDEX - FRANCE
TEL : 33 2 40 09 10 11
EXPORT DEPARTMENT FAX : 33 2 40 09 10 97
www.manitou.com

MANISCOPIC

MLT 526 TURBO 24''

- Maximum lifting height : 5.25 m
- Capacity : 2600 kg
- Maximum forward reach : 2.80 m
- Torque convertor





MLT 526 TURBO 24"

 **Lifting capacity**2600 kg
at 500 mm from forks heels.
Tipping load
at maximum reach :1830 kg
Tear out force with bucket
to ISO 83134160 daN

 **Lifting height** :5.25 m
Times : unladen/loaded (in s)
Lifting.....6.80/7.10
Lowering.....4.80/4.70
Boom extension.....4.00/4.10
Boom retraction.....2.00/2.00
Time unladen (in s)
Crowd3.30
Dump.....2.70

 **Tyres**
17.5 LR 24

 **Forks** (mm)
Length1200
Width x thickness.....125 x 45
Maximum distance between forks1163
Carriage rotation154°

 **Oil bath multidisc brakes on front and rear axles**

 **Perkins engine**
Turbo 1004.40 T3990 cm³
Power (ISO/TR 14396).....104 HP/74.6 kw
Maximum torque.....402 Nm at 1400 tr/mn
Direct injection
Water cooling

 **Transmission**Torque Converter
Electro - hydraulic reversing shift
4 speeds forward and reverse
Maximum travel speed.....34 kph

 **Hydraulics**
Lifting/tilting pump :
gear type90 l./mn - 250 bars
Flow divider with priority to steering

 **Capacities**
Cooling system17.25 l.
Engine oil8 l.
Hydraulic oil135 l.
Transmission oil.....11 l.
Fuel tank104 l.

 **Weight unladen** (with forks)5840 kg
Overall width2.17 m
Overall height2.30 m
Turning radius (outside wheels)3.75 m
Overall length4.51 m
Ground clearance0.49 m
Drawbar pull :6750 daN

Reach at maximum height : 0,50 m

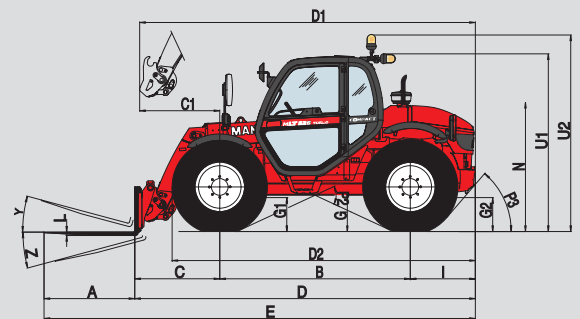
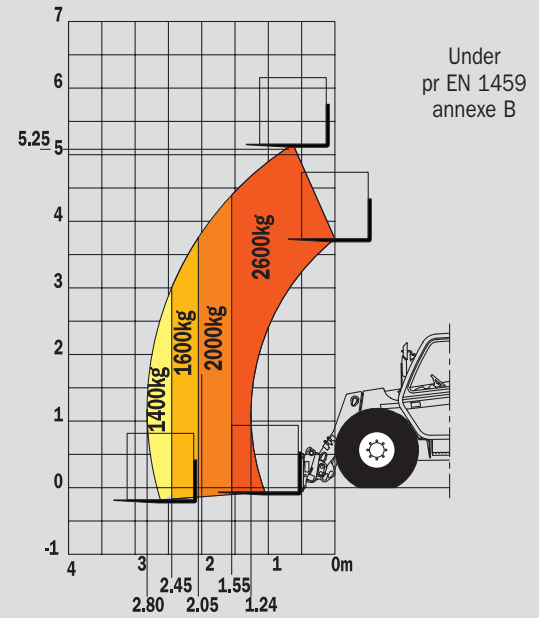

	MLT 526 T 24"
A	1200
B	2520
C	1135
C1	1060
D	4515
D1	4440
D2	4010
E	5715
F	1720
F1	1720
G	490
G1	455
G2	445
I	860
J	866
K	1163
L	45
N	1705 at 1730
O	125
P2	50°
P3	49°
R	3525
S	7345
T	3735
U1	2300
U2	2560
V	4760
V1	1450
V2	3750
W	2170
Y	12°
Z	142°

(mm)

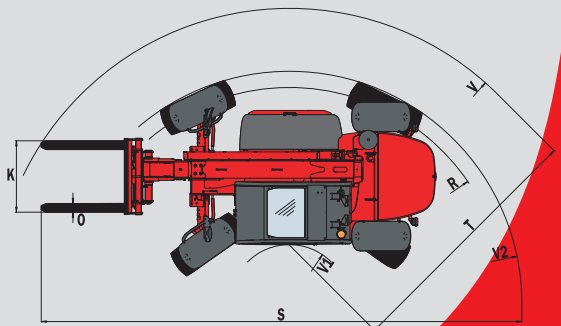
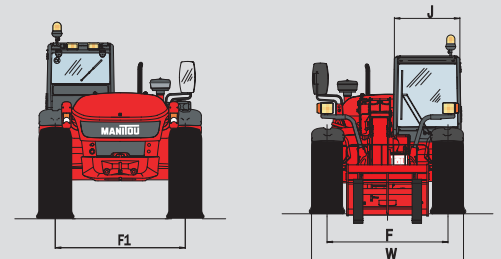

This publication in no way constitutes an offer and the company reserves the right to alter specification without prior notice. Model illustrated may have optional equipment which is available at additional cost.

