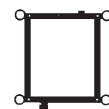

ALIMAK**SCANDO[®] M 1200, PM 1150 & 1050****Technical Data**

| CAPACITY | | SCANDO | | |
|--|-------|--------|---------|---------|
| | | M 1200 | PM 1150 | PM 1050 |
| Pay-load capacity | kg | 1200 | 1150 | 1050 |
| Erection load | kg | 1200 | 1150 | 1050 |
| Speed 50 Hz/60 Hz | m/min | 28 | 28 | 28 |
| Max. lifting height | meter | 100 | 100 | 100 |
| Increased lifting height on request | | | | |
| Erection crane capacity | kg | 150 | 150 | 150 |
| Safety device | type | GF | GF | GF |

CAGE DIMENSIONS

| | | | | |
|-------------------------|-------|-----------|-----------|-----------|
| Internal width x length | meter | 1.3 x 2.0 | 1.3 x 2.0 | 1.3 x 2.0 |
| Internal min. height | meter | – | 1.98 | 2.47 |

ELECTRICAL DATA

Power supply range 380 – 690 V, 50 or 60 Hz, 3 Phase

At 400 V/50 Hz:

| | | | | |
|---------------------------|-----|-----|-----|-----|
| Power supply fuses | A | 35 | 35 | 35 |
| Rated power cont. duty | kW | 7.5 | 7.5 | 7.5 |
| Rated power 25% int. duty | kW | 9.5 | 9.5 | 9.5 |
| Starting current | A | 100 | 100 | 100 |
| Power consumption | kVA | 13 | 13 | 13 |

Data at other voltages on request

WEIGHTS

| | | | | |
|---------------------------|----|------|------|------|
| Base unit weight | kg | 1050 | 1050 | 1050 |
| 1508 mm long mast section | kg | 130 | 130 | 130 |

Optional equipment: Ground enclosure

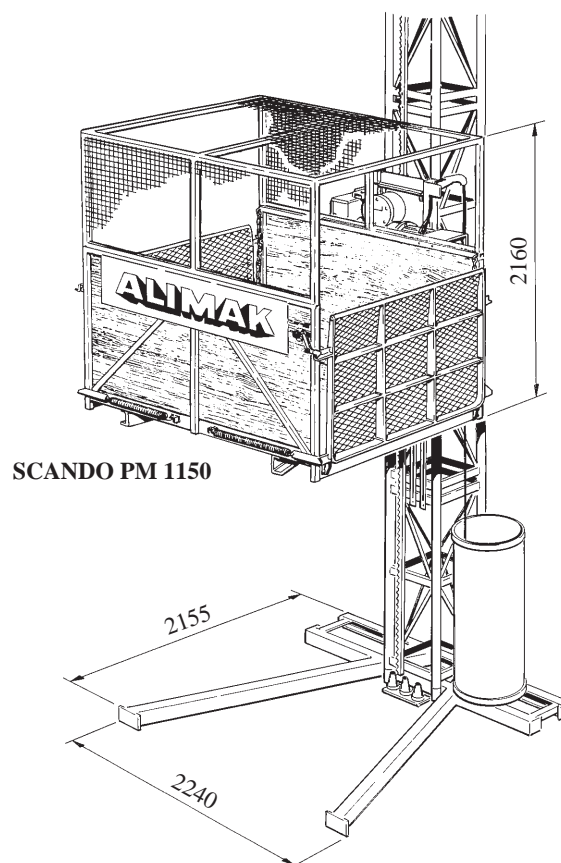
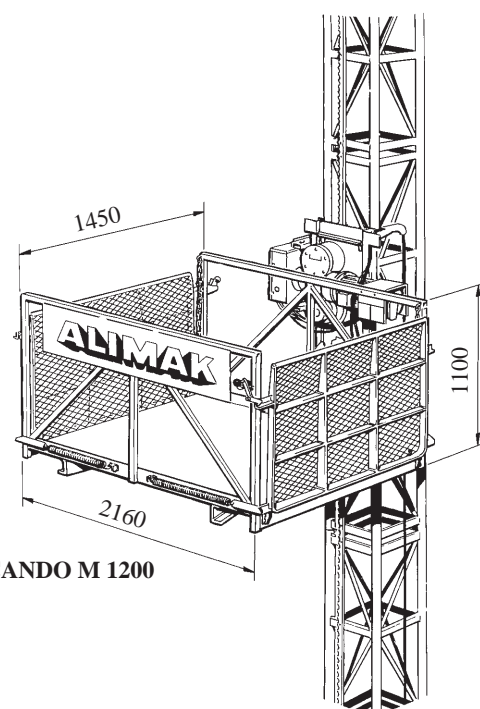
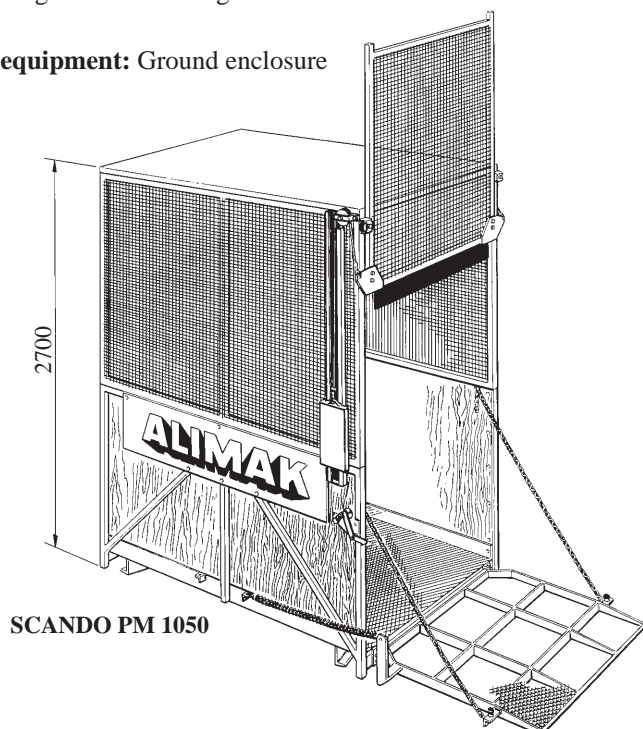



MEMBER OF THE ATLE KAROLIN GROUP

Alimak AB, P.O. Box 720, S-931 27 Skellefteå, Sweden.
Tel. +46 910 87000. Fax +46 910 56690.
E-mail: info@alimak.se Internet: <http://www.alimak.se>

Alimak have subsidiaries in: Great Britain, Germany, France, USA, Canada, Australia, Singapore, Brazil, Italy as well as in South Korea and, furthermore, 40 independent distributors around the world.

Pictures are illustrative only and do not necessarily show the configuration of products on the market at a given point in time. Products must be used in conformity with safe practice and applicable statutes, regulations, codes and ordinances. Specifications of products and equipment shown herein are subject to change without notice.